



# TIMBER TIMES

On the Web at: <http://www.woodcny.org>

On Facebook – WoodCNY

Volume 7, Issue 21  
February 2024



The Woodworkers of Central New York is a Chapter of the [American Association of Woodturners](#)

## FEBRUARY EVENTS

Wednesday, February 7<sup>th</sup>  
@6:30pm

Woodworking SIG Demo

The Little Red Wagon with Jim Yonkers

See \*\* below for location info

Tuesday, February 13<sup>th</sup>  
@6:30pm

Turning SIG Demo

Turning a Peppermill with Rod Castle

See \*\* below for location info

Thursday, February 15<sup>th</sup>  
@6:30pm

Carving SIG Workshop

Carving a Rose—Part 2 with Gary Morison

In Person in Community Room at Beaver Lake Nature Center, 8477 East Mud Lake Road, Baldwinsville

Saturday, February 17<sup>th</sup>  
9am -noon

Club Workshop at Eight Acres Event Center, Baldwinsville  
[address sent week of event]

Wednesday, February 21<sup>st</sup> @  
6:30pm

Scrolling SIG Demo/Discussion

Compound Cutting

See \*\* below for location info

Thurs, Feb 22—Sat, Feb 24  
from 8:30am—4pm

Demonstrate During NYS Farm Show in Witter Museum

See right for detail

\*\* In Person in Community Room at Belgium Cold Springs Fire, 7920 River Rd, Baldwinsville or [Via Zoom](#) [link to be sent week of meeting]

## CLUB DEMOS DURING 2024 NYS FARM SHOW



The New York State Farm Show takes over the NYS Fairgrounds from Thursday, February 22<sup>nd</sup> to Saturday, February 24<sup>th</sup>. Several buildings are filled with an incredible selection of farm-related equipment and services. During this time, the Daniel Parrish Witter Agricultural Museum opens its doors to visitors. And, as one of the big demonstrators for the Museum, the club demonstrates its skills to the visitors. The hours are short—8:30am to 4pm daily. And, we can use electrified equipment for our demonstrations.

### WHAT CAN YOU DO?

*STEP UP TO DEMONSTRATE OR EVEN JUST HELP WITH SETUP*

**WHERE?** The Witter Agricultural Museum is opposite the Coliseum on the New York State Fairgrounds just north of Syracuse.

**WHERE DO I PARK?** Unlike during the Fair, you can park nearby if not right across from the Museum.

Instructions and a map will be provided to all who sign-up by Monday, February 19<sup>th</sup>.

**WHAT EQUIPMENT WILL THE CLUB HAVE THERE?** There will be at least 2 club Rikon lathes, the club Pegas scrollsaw, another scrollsaw, the two workbenches, and tools. Other equipment may arrive, it depends on who signs up!

**ARE WE SELLING ANYTHING?** No – Just the club and woodworking!

**ANYTHING SPECIFIC PLANNED?** For scrolling, there will be small puzzles ready to have their inside cuts done and handed to kids for a gift. And, there will be blanks ready for compound cutting. For turning, there is spindle stock there and Charlie will bring some bowl blanks. For carving, well, the carvers should bring their supplies, including chairs.

Continued on Page 2



## 2024 NYS FARM SHOW, *CONTINUED*

### INSIDE THIS ISSUE

|  |       |
|--|-------|
| NYS Farm Show Demos                      | 1-2   |
| February 2024 Events                     | 3-4   |
| Club Workshop                            | 4     |
| Memberships & Renewal                    | 5     |
| New Woodworking School                   | 5     |
| Mike's Corner                            | 6     |
| Wood Education – Japanese Pagoda         | 7     |
| Tool Talk–Lathe Speed                    | 8     |
| NWA Showcase & Totally Turning           | 9     |
| Club News                                | 10-11 |
| Beads of Courage Boxes                   | 12    |
| Tool Raffle                              | 12    |
| Educational Scholarship                  | 13    |
| Tops Needed!                             | 13    |
| Shop Time & More Shop Time               | 14-15 |
| Show & Tell – Jan 2024                   | 16-19 |
| Turner's Monthly Challenge               | 20    |
| January 13, 2024 Workshop                | 21    |
| Wood Drying Box                          | 22-3  |
| Finishing–Warm & Dry Beats Cool & Damp   | 23    |
| Your Help Still Needed!                  | 24    |
| Corporation & Leadership Information     | 25    |
| Crafts for Charities–Donations Needed    | 26    |
| Videos of Past Demonstrations            | 27    |
| Sending Photos                           | 27    |
| Corporation Supplies, etc.               | 28    |
| Sharpening Services                      | 28    |
| American Association of Woodturners Info | 29    |
| In-Person Classes                        | 29    |
| Classes, Events & Symposiums             | 30    |
| Directions to Locations                  | 31    |
| Meeting Schedules                        | 32-33 |
| Classifieds                              | 34    |
| Area Lumber Suppliers                    | 34    |

**“FAIR RAFFLE” AREA** This area to the left of the fireplace will again house a TV with a slide show and like last year, there will be a collection of toys there for kids to play with. We also encourage you to bring some of your projects to show off to the visitors.

**WILL WE HAVE THE NEW CUSHION FLOORING?** Yes, it remains there! It does make a difference!

**DO I NEED A CHAIR?** There are benches and some stools but you may want to bring your own seating.

**ANY DOWNSIDES?** Yes, a couple. There is no water in the building so you must go to the Expo Center or Dairy Building to use a restroom. We are told “the heat is working”. Hopefully, we will be having a warm spell but we encourage you to dress in layers. No, we can't put a fire in the fireplace as it hasn't been inspected or cleaned in years!

### HOW CAN I HELP?

**Help with Setup** – 11am on Wed, February 21<sup>st</sup> at the Museum.

**Help with Equipment Transport** – Load at 10:30am, Wed, Feb 21<sup>st</sup> from Eight Acres

**Help with Pack-Up & Transport** – Saturday, Feb 24th at Museum

**Offer to Demonstrate and/or Just Chat with Visitors** – Each Day; you can stay the whole day or part!

**HOW DO I VOLUNTEER?** - It's simple. If you have not done already, send an email to woodcny@gmail.com with your plans. No one will be turned away! Include in the email your plans.

**WHAT THEN?** Further communications will come via email from woodcny@gmail.com. Make sure you have it listed as a safe sender!

**SEE YOU THERE!**



Woodworkers at 2023 New York State Farm Show

## FEBRUARY 2024 EVENTS

### WOODWORKING SIG *THE LITTLE RED WAGON* WEDNESDAY, FEBRUARY 7<sup>TH</sup> – 6:30PM

The Woodworking SIG presents an *The Little Red Wagon* with Jim Yonkers for its February 7<sup>th</sup> meeting.. We hear that Jim will be walking everyone through the process of building this type of all-purpose wagon in this session. This should be a another great session so plan to be there!

Don't forget your *Show & Tell* projects for discussion!



### TURNING SIG *TURNING A PEPPERMILL* TUESDAY, FEBRUARY 13<sup>TH</sup> – 6:30PM

Rod Castle makes beautiful peppermills and often shows them at meetings. For February, the Turning SIG brings *Rod* to the lathe to demonstrate his process for creating the peppermills. He's working on a new style peppermill and he will speak about his experience creating this unique style.

The Monthly Challenge for the February meeting is an embellished project (of any kind) using the information provided by Robert Love at the January demonstration.



Typical Rod Mill Set

Both the Woodworking and Turning SIG sessions will be available as a hybrid session—both in-person and via Zoom. We hope many of you will join us in-person, handle your membership renewal, and bring your *Show & Tell* items. All members will receive a reminder with the Zoom link a few days before the events. Can't make it or viewing via Zoom but have projects to show? Send an email with photos and a description to [woodcny@gmail.com](mailto:woodcny@gmail.com) by 3pm on the day of the event to be included in the slide show! Earlier is very much appreciated!

## DEMONSTRATION LOCATION & INFORMATION

The Woodworkers, Turners & Scrollers demonstrations are held **In-Person** in the **Community Room at the Belgium Cold Springs Fire Dept, Station One, 7920 River Road, Baldwinsville.** *Directions on page 29.*

When possible, we will also broadcast the demo via **Zoom** and distribute the link to members 1-2 days ahead. Our Zoom sessions open by 6pm

**Show & Tell:** Items accepted in-person. If you can't make it, send photos and descriptions of your projects to [woodcny@gmail.com](mailto:woodcny@gmail.com) by 3pm on the day of the demonstration so they can be incorporated into the slideshow.

**ALWAYS  
CHECK THE  
WEBSITE FOR  
THE LATEST  
EVENT INFO**

Continued on Page 4



## FEBRUARY 2024 EVENTS, *continued*

### CARVING SIG – CARVING A ROSE, PART 2 THURSDAY, FEBRUARY 15<sup>TH</sup>—5PM-8:15PM

The Carving SIG will meet on Thursday, February 15<sup>th</sup>. Gathering will start at 5pm and we expect to start carving by 6pm. During this session, **Gary Morison** will work with attendees to continue **Carving a Rose**. This is a 3-part workshop, with more work to be done at the March 21<sup>st</sup> meeting. Don't forget your **Show & Tell** items also.

The Carvers meet in the large Community Room at the *Beaver Lake Nature Center, 8477 East Mud Lake Road, Baldwinsville, NY. Directions on page 31.*

### CLUB WORKSHOP

### SATURDAY, FEBRUARY 17<sup>TH</sup> 9AM—NOON

The Club will hold another monthly workshop on February 17<sup>th</sup>. The workshop is held at the large garage at Charlie & Barbara's home, a location affectionately known as the *Eight Acres Event Center*. The garage includes a shop space that is heated where 7 lathes are housed and available for use by attendees. The outer, unheated area, houses the club's grinder for sharpening tools, a very large stash of wood available for purchase, an area with the club's consumables, and space to gather in warmer weather.

We welcome all members to attend, learn to turn, learn to scroll, learn to carve, and otherwise participate at workshops, even if just to chat! If a member wishes instruction on other topics, they can request it and if it cannot be handled on the normal workshop day, Charlie will work with them to schedule another time.

**NOTE:** Wood and consumables items can be purchased at *ANY time*. You do not have to wait for a workshop day. Contact Charlie at any time either at 315-720-7151 or [8acreswood@gmail.com](mailto:8acreswood@gmail.com) to arrange a time to purchase whatever you need.

### SCROLLING SIG – COMPOUND CUTTING WEDNESDAY, FEBRUARY 21<sup>ST</sup>—6:30PM

The Scrolling SIG will meet on Wednesday, February 21<sup>st</sup> at 6:30pm to learn compound cutting. Bring your baskets and/or bowls based on our 2023 demonstration along with other projects to share with everyone during **Show & Tell**.

The Scrollers meet in the Community Room at the Belgium Cold Springs Fire Dept, Station One, 7920 River Road, Baldwinsville. We hope to broadcast via Zoom but will definitely have an in-person event.

## MEMBERSHIP & RENEWALS

The Woodworkers of Central New York (WWCNY) continues to attract members from near and far. Since the New York State Fair, we've received new memberships from 25 people so our total membership is over 300! Within that 25 are 5 youth who we hope will actively attend meetings/demos, learn, and participate in our events.

Membership in the WWCNY runs from January 1 to December 31. Anyone who joins from October 1 forward automatically receives their membership for the following year. We do receive members throughout the year but do no prorate memberships based on when you join. The Board continues to keep the membership price reasonable at just \$25 for individuals and \$35 for families, with Juniors free (with an adult membership).

The Board realizes that many members used our online with PayPal option to renew/join in the past. Unfortunately, PayPal requires a member's social security number in addition to our Federal Tax ID # for our account. After this discovery, we cancelled that account. We are working on another option.

For now, we ask that you pay with either cash or checks, however, Barbara can use the Square account used for craft show sales if you want to use a credit card.

Renewals can be taken at any of the upcoming meetings, workshops, and other events. Or send a check by mail to the corporate address:

Woodworkers of CNY, 3405 Patchett Rd, Baldwinsville, NY 13027

### BE SURE TO:

*Either complete the 2024 membership application (on web) or include a note with your current email and phone number so we can update the records!*

**DON'T MISS OUT ON INFORMATION ON EVENTS!  
RENEW TODAY!**

## A NEW WOODWORKING SCHOOL, IN NYS!

Looking for woodworking classes? A new, non-profit school is opening in April in Scottsville, NY, 10 miles south of Rochester!

The Wendell Castle Workshop will be housed in Wendell's longtime studio.

Often referenced as the "Father of the Art Furniture Movement", he was included in the "Big 4" of modern woodworking with Wharton Esherick, George Nakashima, and Sam Maloof.

Several of his former employees along with other nationally known makers will be the instructors at this school. Classes and instructors are listed on their website—[wendellcastleworkshop.org](http://wendellcastleworkshop.org).

The only other woodworking school in NYS is the [Adirondack Folk School](http://Adirondack Folk School) in Lake Luzerne. If you attend this school (or any school), please consider submitting an article for the newsletter about your experience.



**RENEWALS ARE  
UNDERWAY**

**Due by March  
31, 2024!**

Have a question about membership? Email [woodcny@gmail.com](mailto:woodcny@gmail.com) with your question!

## MIKE'S CORNER LAMP BASE GLUE-UP

Mike Vecellio shares a variety of techniques he's learned with other members whenever possible. Here he talks about click pen mechanisms. *Your articles are welcome anytime.* Please send to [woodcny@gmail.com](mailto:woodcny@gmail.com).

### Where Does Mike Buy His Pen Kits?

Mike's favorite place to buy kits is a website named [Exotic Blanks](#).

Why? Great service along with several kits with Schmidt mechanisms. [Plus usually some candy with each order!]



Figure 2

I don't think of myself as being very creative, but I wanted to come up with something different for last month's lamp challenge. *Figure 1* shows what I ended up with for the glue-up.

I started out with a piece of maple stock that was 1½ inches square and 11 inches long. Then I glued two pieces of cherry to 2 opposite sides of the maple. I ran that through my thickness sander to make the edges perfect.

Next, I glued 2 pieces of walnut to the other 2 sides and, again, ran the block through my thickness sander to make the edges perfect. The next layer was butternut which I glued to the same sides as the cherry. Next came a layer of maple against the walnut sides. Finally, I added a layer of walnut all around the entire block.

I let each layer dry completely before adding the next. After squaring up the ends, I drilled a two-inch hole in the bottom with my Forstner bit 1½ inches deep for mounting with a chuck. Before turning I cut the corners off to make the turning easier.

I had absolutely no idea what the final project would look like or what shape I going for. I turned the block round then shaped the block until I liked the final look. I sanded from 100 grit up to 400 grit then finished the lamp with wipe on polyurethane. While still on the lathe, I drilled a 3/8" hole as far into the lamp as I could with a 3/8" brad point drill bit. The last thing I did before removing it from the lathe was to drill a 5/16" hole

1 inch from the bottom for the wire.

After removing the lamp from the lathe, I finished drilling the 3/8" hole through the lamp with a long 3/8" bit. I believe that the brass threaded tube needs to go completely through the lamp.

All the lamp kits I found, either online or local, only came with a short tube for the top and with a 3-way switch. I bought the single throw switch and long brass tube separately. I also purchased some 5/16 snap grommets to protect the wire whenever it passes through the tube or wood.

*Figure 2* shows a close-up photo of the final lamp. Unfortunately, I was unable to attend the January meeting, so weather permitting, I will bring the lamp for *Show & Tell* next month .



Figure 1

## WOOD EDUCATION — JAPANESE PAGODA

At the January turning meeting, Charlie showed a small box made of Japanese Pagoda. Let's explore this wood.

*Japanese pagoda* (*Styphnolobium japonicum*) is also known as *Chinese scholar tree*. It is a showy, medium to large, deciduous flowering tree. It has a rounded crown and grows to a height of 50 to 75 feet and is equally as wide. It is grown for its attractive green foliage and fragrant summer flowers. The flowers are white, pea-like, and hang in 12-inch-long panicles. Pods appear in the fall and persist through the winter months. Its showy leaves remain green on the tree late into the fall, thereby shortening the length of time for its yellow fall color.

The Japanese pagoda tree is native to China. It is found growing in thickets and upland forests along rocky mountain slopes in its native habitat. The bark is grayish-brown with reddish-brown furrows as it ages. The stems remain green for 3 to 4 years before changing to brown.

The Japanese pagoda tree is a good urban, street, park, or lawn tree. When grown in the open, it tends to

branch low to the ground. However, with proper care, it can be formed to grow into a tall specimen with an erect trunk.

The pagoda tree trunk is generally composed of alternating ridges of light-brown outside layers and gray brown inside layers. Pagoda wood is very hard after drying. It is highly resistant to rot and decay, highly resistant to termites, relatively lightweight and easy to work.

### Fun Facts:

- ◆ The seed pods form after flowering is complete and appear like beads on a string.
- ◆ The seeds have a sour taste and are toxic.
- ◆ The flowers and leaves are sometimes used for teas
- ◆ A yellow dye can be obtained from the flower buds. Ancient Japanese prints used this dye.
- ◆ The flower buds are used in Asia in traditional medicine as an astringent.
- ◆ The timber is used for making furniture and for construction.
- ◆ It is also used in traditional Japanese medicine for its anti-inflammatory, antioxidant, and anti-cancer properties



## TOOL TALK –LATHE SPEED

At what speed should you turn? Larry Prunotto shares this article for our turners. *Your articles are welcome anytime.* Please send to [woodcny@gmail.com](mailto:woodcny@gmail.com).

How fast is your lathe going? That is a frequent question during demonstrations and workshops. It is often believed that to produce the same results, someone needs to turn at the same speed. The presenter may or may not tell the speed but generally with a caveat that different people turn at different speeds. Sometimes, they don't tell often because their lathe doesn't have a speed indicator.

The question may then result in a discussion with cautions based on different conditions and product dimensions. Rediscovering the table, let's clarify *recommended* lathe speeds.

After reviewing the table, there are other considerations to be considered:

- ⇒ Experience of the lathe operator
- ⇒ Condition of material being turned
- ⇒ Purpose of the turning action

The general ratio recommendation (rpm x diameter range - 9,000 to 12,000) is usually presented. This is for general guidance that addresses cutting effectiveness and keeping material cutting surface speeds to a maximum. A more detailed guidance is justified.

The table is from a Powermatic Lathe Manual. It provides conservative (max ratio of 9000) and more specific guidance to diameter and specific actions (roughing, general, and finishing). The purpose of slower rpms during roughing helps minimize splintering and vibration. Faster speeds and lighter touch cuts are for finishing which should result in fewer imperfections and less of a tendency for tear out. Ultimately, this means a safer cut that requires less sanding.

In any event, use these recommendations as good practice limits, and always turn at a speed within your comfort level.

### 14.0 Recommended lathe speeds (per diameter of workpiece)

| Diameter of Work | Roughing RPM | General Cutting RPM | Finishing RPM |
|------------------|--------------|---------------------|---------------|
| Under 2"         | 1520         | 3000                | 3000          |
| 2" to 4"         | 760          | 1600                | 2290          |
| 4" to 6"         | 510          | 1080                | 1500          |
| 6" to 8"         | 380          | 810                 | 1125          |
| 8" to 10"        | 300          | 650                 | 900           |
| 10" to 12"       | 255          | 540                 | 750           |
| 12" to 14"       | 220          | 460                 | 640           |
| 14" to 16"       | 190          | 400                 | 560           |
| 16" to 20"       | 175          | 325                 | 450           |
| 20" to 24"       | 175          | 260                 | 375           |

Table 3

Remember, this is only a recommendation. You should read and understand instructions that are provided with your lathe. It is also suggested that you join the American Association of Woodturners (AAW) and review resources available on their [website](#) such as *Woodturning Fundamentals*.



## UPCOMING EVENT

### NWA SHOWCASE & TOTALLY TURNING

#### MARCH 23-24—SARATOGA SPRINGS CITY CENTER



The *Northeastern Woodworkers Association* – the woodworking club that covers eastern New York—holds a woodworking show each spring. Called the *Woodworker's Showcase*, 2024's edition will be the 32<sup>nd</sup> year for the event.

Several years ago, the NWA SIG called the *Adirondack Woodturners Association* moved their turning symposium, *Totally Turning*, from October to March to be held concurrently with *Showcase*.

For 2023, the dual event will be held **Saturday, March 23 and Sunday March 24** at the **City Center in Saratoga Springs**.

The events share a vendor hall as well as other City Center spaces. Each event has their own cost structure, speakers, and galleries. Both events are run by volunteers.

Several of our club members attend one or the other event and will gather for meals on both Friday and Saturday evenings. Here are particulars on each event.

#### WOODWORKER'S SHOWCASE

Showcase admission includes entry into the vendor hall, the large gallery space, classes on numerous aspects of woodworking, kids toy building, pen turning class, and demonstrations. **Four** members of our club are demonstrators **Mike Bloomquist, Harold Kaltenbach, Charlie LaPrease** and **Barbara Raymond-LaPrease**. The schedule is on the event website. The price of a ticket is \$15 at the door or presale via their website is \$17.85, with children 12 and under free. For 2024, they are offering group discounts for 15 or more adult tickets receiving a 10% discount.

The gallery is open to all – *including you as a WWCNY member* – as long as your project arrives by **6:45pm on Friday, March 22<sup>nd</sup>**. There are 23

standard categories in which you can enter projects (*see right*). You **MUST** submit an entry form before March 21<sup>st</sup> to enter pieces in the gallery. Judging happens on Friday evening. *ORNAMENTS* is the 2024 Challenge (*details on the website*).

#### TOTALLY TURNING

Admission to the woodturning-focused event called *Totally Turning* includes early entry each day into the vendor hall which includes their gallery space. More so, it includes admission to all 48 turning-based classes held in 6 different rooms over the two days from 8am to 5pm each day. *This is 8 more rotations than in 2023*.

The demonstrators for 2024 are **Barry Gross, Mauricio Kolenc, Janice Levi, Mike Mahoney** (remotely), **Matt Monacop, Graeme Priddle & Melissa Engler, Derek Weidman, Karen Amodeo**, and **Joe Larese**.

You also receive a T-Shirt with registration, coffee and breakfast service, and optional pre-order lunch. Demonstration rooms will have upgraded camera, projection, and sound systems.

The cost for *Totally Turning* is \$225 advance registration, \$245 with lunch option. Children 12 or younger are \$25. Online registration ends March 19<sup>th</sup> at midnight.

#### LODGING FOR BOTH EVENTS

There are several hotels in the Saratoga area. Most attendees stay at *The Saratoga Hilton* to which the City Center is attached. The rate for 2024 is \$149 per night plus taxes & fees for a standard room. A link to the hotel website that includes the discounted rate can be found on both event pages.

NWA Webpage: [woodworker.org](http://woodworker.org)

#### SHOWCASE GALLERY CATEGORIES

Accessory 1, 2, & 3  
Adirondack  
Alternative Materials  
Boats  
Carving 1, 2, 3, & 4  
CNC-Laser  
Furniture 1, 2, & 3  
Intarsia  
Jewelry  
Pyrography  
Scaled Models  
Scroll  
Shop Equipment  
Toys  
Wooden Instruments 1 & 2  
Challenge—Ornaments

Descriptions of each category and the entry form can be found on the website [HERE](#).

#### TOTALLY TURNING GALLERY CATEGORIES

Bowls  
Platters  
Pens  
Artistic/Jewelry  
Spindle  
Hollow Forms  
Segmented  
Alternative Materials  
Novice  
Master Division  
2024 Special Category  
— Spinning Tops

Descriptions of each category and the entry form can be found on the website [HERE](#)

## CLUB NEWS

The Board of Directors held its bi-monthly meeting on January 24th. During that meeting, we covered a large variety of topics. They are summarized here for your reference.



- ◆ **SUMMER SOIREE / EDUCATION DAY** – The date is **Saturday, July 20<sup>th</sup>** from 9am to 4pm.
  - ◆ **Confirmed Demos** – The British Blacksmith, Fire Extinguisher training with a prop so you can practice, Old Tool Display & Hands-On demo and you are encourage to bring yours, and Lumber Milling.
  - ◆ **Other Demos**—We are looking for your ideas or for you to volunteer
- ◆ **WOODWORKERS CHALLENGE** – Several changes are being made for the 2024 Challenge.
  - ◆ **Date** – With many members relocating starting in early November and the conflict with Veterans Day, we decided to move the Challenge to October. The date for 2024 is **Saturday, October 19<sup>th</sup>**.
  - ◆ **Category Changes**
    - ◆ **Out** – *Sculpted and Turning-Other*
    - ◆ **New** – *Ornaments (all kinds) and Pens*
    - ◆ **Modified** – *Toys will be broken into 2—Large Toys and Small Toys—guidelines regarding size will be added to the descriptions.*
    - ◆ **What Not** – Revised wording for this category will be created that guides entrants regarding limitations
  - ◆ **Pre-Registration** will be encouraged and anyone pre-registering will be entered in a gift certificate raffle. On-site registration will be allowed but the preference is to have people pre-register.
  - ◆ Categories will be divided with tape prior to judging to ensure you are judging the correct entries. The new voting per category will continue as it reduces the time for counting. A check to verify entries are correct will also be conducted prior to voting.
- ◆ **EVENT DATES SUMMARY** – Several people commented that they don't know when events are happening. While emails are sent and the website is updated constantly, members will receive a document summarizing dates of events. This list can change but it is a start.
- ◆ **CRAFTS FOR CHARITIES** – We will be selling at the Beaver Lake Harvest Festival (September 7-8) and Manlius Historical Society event [*which includes demos*] (date TBD). Otherwise, we are looking for 2-3 people to step up and sell at any other events.
- ◆ **TOOL SWAP / AUCTION**— We are looking at bringing back this popular event, maybe as a subset of the Summer Soiree. More details to follow.
- ◆ **INFORMATION & STATUE STANDS FOR MUSEUM** – We need to build about 8 new stands to hold information about each station in our demo area at the Museum. Also, there is a very heavy bust of Richard Lamp Allen that needs a stand. If you would like to help let us know.
- ◆ **PINEWOOD DERBY**—**Sunday, February 11**, 2-4pm—We've been asked to help again. If interested, please let Barbara know at [woodcny@gmail.com](mailto:woodcny@gmail.com)

## CLUB NEWS, CONTINUED

- ◆ **NEW YORK STATE FAIR RAFFLE**—Donations are needed from each interest area. Notify Barbara before July 1<sup>st</sup> if planning to donate an item. All items must be provided by August 1<sup>st</sup>. Need to see donations from previous years? Go to the club website—[www.woodcny.org](http://www.woodcny.org)—and look at the *NYS Fair Demonstrations* page under *Community Support*. Scroll down to see photos of past raffle items.
- ◆ **CLUB CLOTHING**—We are working with a local vendor to setup a website where you will be able to order various club clothing. More to come.
- ◆ **Ornament Challenges**
  - ◆ **As Wood Turns Annual Challenge**—The entry time is November but you are encouraged to start now for 2 reasons:
    - ◆ The **Challenge** category for the annual Northeastern Woodworkers Showcase event on March 23-24 is **Ornaments** with the following specifications—no larger than 6” tall by 4” wide by 4” deep, weigh less than 0.5 pound, capable of hanging, and using any woodworking method.
    - ◆ You do not have to attend to enter **IF and ONLY IF** you deliver your ornament to Barbara by 5pm on **March 17<sup>th</sup>** (there is a workshop on March 16<sup>th</sup>) **AND** you complete the submission paperwork on the NWA website—<https://woodworker.org/about-showcase/>
  - ◆ The Turning SIG **Monthly Challenge** for the May 14<sup>th</sup> meeting is an ornament. The Scrolling SIG always accepts ornaments for our Crafts for Charities sales and your ornaments can be added to the November contest as what happened last year.
  - ◆ **Crafts for Charities Ornament Donations** — All ornaments are always welcome along with other items to refill the boxes for our sales. As noted later, we have a need for sea urchin ornaments, hollow ball ornaments with finials, bird houses, and many other ornaments. See page xx for a summary of our needs!
- ◆ **DEMONSTRATION IDEAS & DEMONSTRATORS**—We are looking for your ideas for topics of demonstrations as well as demonstrators. There are demonstration openings for each Special Interest Group (SIG). Please contact any of the SIG leaders with your ideas. Their numbers are below:
  - ◆ **Woodworking**  
Charlie LaPrease: [8acreswood@gmail.com](mailto:8acreswood@gmail.com) — 315-720-7151
  - ◆ **Turning**  
Mark Anastas: [anastasmrk20@gmail.com](mailto:anastasmrk20@gmail.com) — 315-863-4483
  - ◆ **Scrolling**  
Barbara Raymond-LaPrease—[woodcny@gmail.com](mailto:woodcny@gmail.com) — 315-345-5381
  - ◆ **Carving**  
Gary Morison: [morisonenterprise@yahoo.com](mailto:morisonenterprise@yahoo.com) — 315-327-9157
- ◆ **2024 MAKER FAIRE**—The Club will be participating in the annual Maker Faire on **Saturday, May 4<sup>th</sup>**. The event will be held in the Horticulture Building at the NYS Fairgrounds. We will spend the day demoing, talking about the club, and in general showcasing our organization. Setup will be on Friday evening. If you are interested in volunteering, please send a note to [woodcny@gmail.com](mailto:woodcny@gmail.com).





Make a Box &  
Bring to ANY SIG  
Meeting or Event

Turned, Scrolled,  
Traditional Box,  
Whatever!!

The folks at the  
Joslyn Center are  
desperate for  
boxes. Please step  
up and make one  
or two (or more!).



## BEADS OF COURAGE BOXES

**B**eads of Courage is a non-profit organization that is dedicated to improving the quality of life for children and teens coping with serious illness, their families, and the clinicians who care for them. Children being treated for life-threatening illnesses are given beads as they undergo a variety of treatments. Boxes are one of the vessels in which they keep their beads.

The Syracuse Joslin Diabetes Center contacted the club requesting that our members make boxes for distribution to kids undergoing treatment for diabetes at the Center. They are looking for boxes of any type whether turned, scrolled, carved, or assembled using traditional woodworking. Members are encouraged to build and donate one or more boxes to fill the Center's urgent needs. Doug North, our president is managing our involvement in the program. Bring the completed boxes to meetings/other events or arrange for their receipt by Doug ([dnorth@twcny.rr.com](mailto:dnorth@twcny.rr.com) or 315-753-1121). We want to track and photograph each donated box.

There are some guidelines for size, finish, etc. We recently clarified the sizes so these are revised guidelines.

### Wood Thickness & Weight:

- ◆ The boxes should not be heavy or bulky. Wall thicknesses should be ¼" to **not more than ½"**. Please, not super thin and delicate.

### Dimensions:

- ◆ **Turned Boxes: Around 6x6" and not larger than 8x8"**
- ◆ **Flatwork Boxes: Not smaller than 6x6x3" and not larger than 8x8x3"**

### Base & Lids:

- ◆ Box bases should be wide enough so the box is stable & does not tip over easily
- ◆ Lids should be easy for small or ill children to remove or lift.
- ◆ Any finials should be easy for a small child to grasp and not too elaborate so they don't break

### Design Consideration:

- ◆ The boxes should be able to transition with the child into adulthood and be a keepsake for many years as the patients life with the diagnosis for a lifetime.
- ◆ Avoid excessively elaborate designs that may easily break or be damaged.
- ◆ If possible, incorporate one of the *Beads of Courage* beads into the box. See Barbara at any meeting to obtain one. The club purchased the beads

### Finishes:

- ◆ Please use a safe, non-toxic finish.
- ◆ Do not use finishes like linseed oil that take a long time to outgas.
- ◆ Refrain from painting the boxes. Instead, highlight the beauty of the wood with clear varnish, a stain, and/or wood burning.

## TOOL RAFFLE

**O**ur next tool raffle is a Proxxon Delta Sander OZI/E, model 38-520 in storage case with a variety of sanding discs.



Raffle tickets will be available at all meetings/events through April. We will draw a winner at the Woodworking SIG meeting on May 1<sup>st</sup>. Tickets are \$1 each or 6 for \$5.

## EDUCATIONAL SCHOLARSHIP

You may have heard mention that the Board of Directors was developing a *Train the Trainer Scholarship Program*. At their September 27<sup>th</sup> meeting, the scholarship form was finalized and we are ready to start rolling it out.

**What Is It?** It is a way for members in good standing to receive money to support their attendance at a training program of their choosing as long as they agree to return and provide club training. The member becomes a “subject-matter expert”.

**What Do I Need to Do Once I Return?** In order to receive the scholarship, you must present a club demonstration and/or workshop training others on what you learned. Additionally, you must provide a summary of the training that can be used in the newsletter.

**How Much Money is Available?** Upon review of the application, the Board will decide how much to fund for the course.

**How Do I Apply?** The draft scholarship form is available on the website under “Home/About/Forms”. There will be a notice on the homepage and link to the form.

**Then What?** The completed form MUST be submitted to the club email account – [woodcny@gmail.com](mailto:woodcny@gmail.com) – at least 90 days before scheduled training. It will then be distributed to the Board of Directors for review. The Board will review at its next meeting. It is suggested that you submit well in advance of the training to ensure the review occurs.

**How Do I Get Paid?** You will be required to submit your payment request to the treasurer using the club’s *Reimbursement Form* (also on the website).



## TOPS NEEDED!

Looking ahead to the 2024 NYS Fair, each year the club sells tops to the attendees as a fundraiser for a couple local charities. We sell enough that we need a stockpile of **600-700 tops!**

Tops can be turned, scrolled, or even made on a laser!

Don’t know how to make a top? Come to a turning workshop to learn! Charlie and others will be happy to show you! Here are three YouTube videos to check out: [Making a Top](#)

[Wood Magazine](#)

[Jason Geiser](#)

[Gwinnett Woodturners](#)

Mike Vecellio provides some great instructions for making tops in two of his past columns – [August 2020 & March 2023](#). Check those out!

Yes, tops can be scrolled also. Interested in patterns? Send a request to [woodcny@gmail.com](mailto:woodcny@gmail.com) and Barbara will send you some.

**Finishing?** The buyers love it when you add color to plain tops. Magic markers work fine! Please no glitter!

**What Do I Do With Them?** Bring to any meeting or event. If you can’t make one, you can always drop them off at Eight Acres, just let us know you are stopping by!

**CHARITIES  
WHO RECEIVED  
PROCEEDS OF  
2023 TOPS SALES**

*Sleep in Heavenly  
Peace Syracuse*

*Make-a-Wish CNY*



## SHOP TIME!

Shop Time is our column that brings you techniques that you can use in the shop. If you have some tips to share, please send to [woodcny@gmail.com](mailto:woodcny@gmail.com).

### Space Saving Router Table

Most woodworkers do not have tons of space in their shop so building work surfaces that hide away when not in use are important. This fold-up router table provides plenty of support for most workpieces but it folds up when not needed!

The drawing gives you an idea of how it works. Stagger your wings so they fold flat, one on top of the other. To locate the upper cleat, flip the top up against the wall. Then to hold the top in place against the wall, add screen door hooks. Finally, lower the top to locate the counterbores underneath for the leveling hardware.

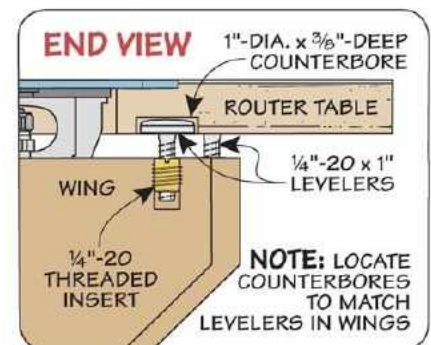
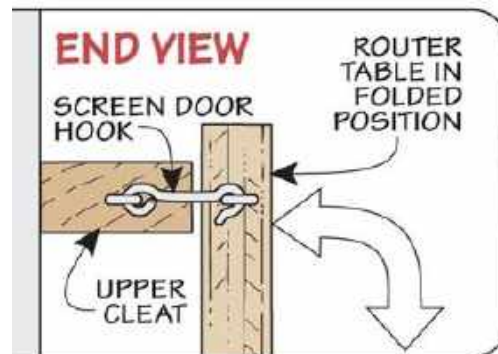
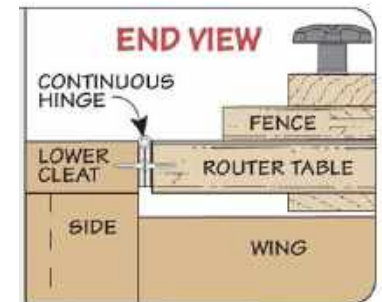
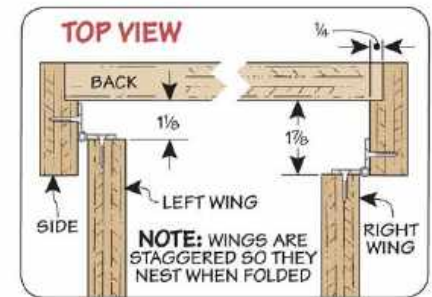
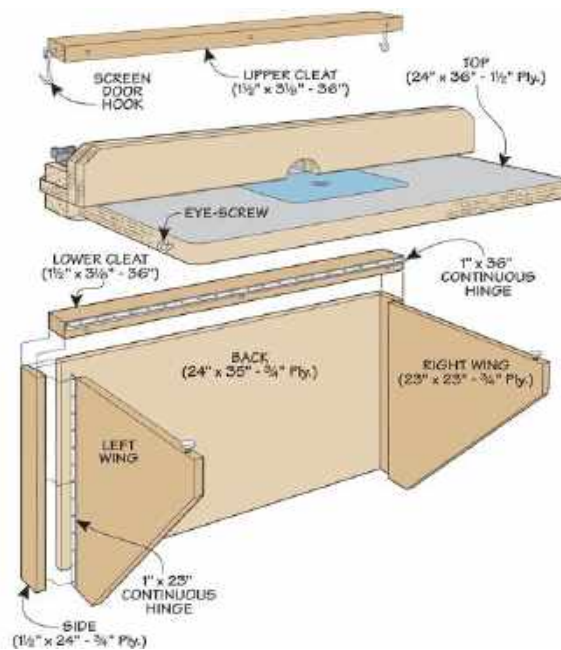

## MORE SHOP TIME!

### Versatile Table Saw Saddle

There are several tasks on the table saw that are just safer to perform using a tall fence. Being able to clamp the workpiece to the fence, adds another measure of safety. Build the sliding tall fence you see in the photo. It's sized to fit snugly over your existing rip fence, but still glide along the fence easily. This fence is a great help when cutting slots for splines, tenons, and a number of other cuts.



As the drawings show, there are a pair of T-tracks and hold downs on the face of the fence to hold a workpiece in position. Braces attached to the horizontal bracket help hold the face of the fence perfectly square to the saw table. You'll need to size the bracket to fit the rip fence on your saw. Then it's just a matter of cutting the face to size and adding dadoes for mounting the T-track. When that's complete, you can attach the face

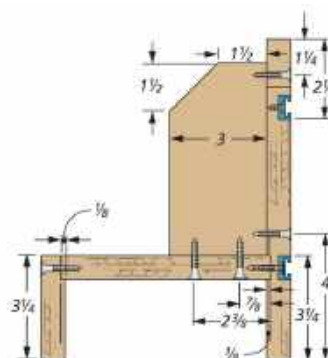
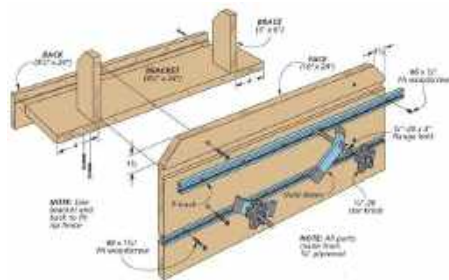

### Save Time—Measure First!

Whether you are assembling boxes, drawers, or furniture you'll want to protect the corners from the band clamps. Make your own from PVC pipe, cutting a 1" wide slot along the length of each piece. The slot allows the PVC to fit over the corners of the project without damaging them.

### Build a Bowl Press For Your Glue-Ups

Are you assembling layers of wood before turning? How are you clamping the wood? Borrow a tip from the scrolling community - *build a bowl press!* What? You see, scrollers are making bowls on their scrollsaws and they are making presses to place even pressure on their bowls when they are assembled.

Want to make a press? There is a great set of plans on the *ScrollMania website* - [www.scrollmania.com](http://www.scrollmania.com). Look under Plans. The website has several other tools including an angle calculator and board foot calculator. Check it out!



# SHOW & TELL – JANUARY 2024

Here are the photos from our *Show & Tell* during the three January meetings as well as some sent by members for the newsletter!



**Don Vanderveer**  
Child's Table & Chairs  
Red Oak  
Danish Oil w/Wipe-On Poly for Durability  
Kreg Jig Pockets Hole Screw & Glue Joints for Sturdy Construction  
*Commissioned*

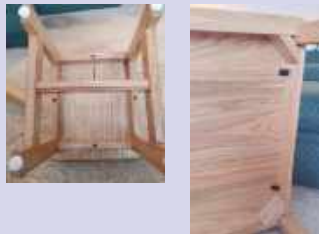

**Tom Lawlor**  
Stanley 45 Combo Plane  
In Storage Box Plus Case for Bits



**Steve Sabella**  
Desktop "Cornhole" Game (Cherry/Oak)  
BlueTooth Speaker (Cherry)  
Pecky Sinker Cypress Slabs from Florida



**Scott Harrison**  
Scrolled Projects  
Wood Milled on Property



**Ray Smith**  
I-Watch Charger Stand  
Walnut  
Ack's Finish

**Rod Castle**  
Two Ash Peppermills  
Winner Pizza Cutter w/ 3D Printed Holder





# SHOW & TELL – JANUARY 2024, PAGE 2



**Mike Shuron (new member from KY)**  
January Output—6 Apache Helicopters; 7 Backhoes, 18 Buses, 16 Tractors (that need trailer), 16 Tractors w/ Loaders, 16 Fire Trucks (needing ladders)  
100+ Small Cars in Blue Bin  
12 Car Carriers [bottom photo]



**Arlene Schlueter**  
*Santa & Sleigh on Skis*



**Dave Weir**  
*Road Kill Santa, Small Girl, Small Gnome House, Toucan*



**John McCabe**  
*Walnut Bowl  
Spalted Maple Bowl  
Odie's Oil Finish*



**Scrolled by Ralph Negrotto & Carved and Painted by Elaine Negrotto**  
*Bears in a Tree  
Birds in Flight  
Harvest Scene*

**Frank Huckabone**  
*Penguin  
Seagull*

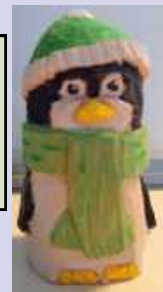

# SHOW & TELL – JANUARY 2024, PAGE 3



**Mike Bloomquist**  
Laughing Woodspirit/Greenman  
Tall Hat Jul Tomte (Swedish Gnome)  
Christmas Tree Gnomes  
Star Gazing Snowman  
Mermaid Pie Crimper

**Gary Morison**  
Rose, Butterfly & Dragon Fly Display  
Gnome Home Wall Hanging  
Skull & Candle



**Jim Yonkers**  
Duck Calls (2)  
Maple Kitcheware  
Cottonwood Gnome House  
Cottonwood Gnome Tree House (Part of a Larger Village Diorama Underway)



**Jim Ruddock**  
Tops Game Board (March Turning Demo)  
Cherry Inside Out Ornament

# SHOW & TELL – JANUARY 2024, PAGE 4



**Charlie LaPrease**  
Ash Bowl from a 1” Board  
Walnut Box  
Japanese Pagoda Boxes  
Osmo Finish



**Jeffrey Watson**  
Barometer with Segmented Turning and Wood Threading  
Wine Cork Frame with Inlay Work.



**Jim Kent**  
Maple Segmented Zipper Vase  
Cherry Lantern Ornament



**Tom Cooney**  
Cat Tree (Occupied!)

## TURNER'S MONTHLY CHALLENGE JANUARY 2024—LAMPS

### February Monthly Challenge

*Any Project  
Embellished Using  
Techniques Shown at  
the January Meeting.*

*It can be a bowl, a  
spindle-type project,  
whatever! You  
choose!*

Each month the Turning SIG conducts a Challenge where members enter a project into a contest that is judged by meeting attendees. The project with the most votes receives a gift card. A second drawing is conducted with remaining entries for a participant gift card. The topic is generally based on the previous month's demonstration.

For January, we had 4 in-person entries for People's Choice plus one extra for participant who sent photos.

**People's Choice — Ray Smith**  
**Participant Award — Paul Depew**



**Ray Smith**  
Red Birch w/Ack's Finish



**Paul Depew**  
Purpleheart, Padauk, Tigerwood,  
Butternut, Sapele, Black Walnut w/  
French Polish Finish



**Mike Vecellio**  
Butternut  
Maple,  
Walnut,  
Butternut, &  
Cherry



**Rick Kiehl**  
Cherry w/  
Osmo Oil  
Donated for  
Craft Sales



**Charlie LaPrease**  
Ash

## JANUARY 13, 2024 WORKSHOP

The January club workshop was another success with most of the lathes operating throughout the workshop plus lots of questions. Everyone enjoyed themselves and learned a ton!



## GREAT INFORMATION FROM THE PAST!

Check out this article that was in the February 2016 former CNY Woodturners newsletter. It bears repeating today for all to read. A photo of the box made by Bruce Meissner is also included for reference.

Chad relocated to Seattle in July 2023 but his instructions remain valid.

## WOOD DRYING BOX

At the January 2016 meeting, Chad Dawson showed the wood drying box he constructed. You can build your own using the information he's provided here! One note ... Chad bought many of his components at Lowe's. Obviously, you can also purchase at Home Depot. *NOTE—The prices quoted here are from 2016 and likely are different today!*



Bruce's Box — Chad's on Page 27

A foam box for drying green wood was built on a style developed by Bruce Meissner. The overall idea is to slightly heat the air with a light bulb (*controlled by a thermostat*) and move only several cubic feet of air per minute (CFM) to create a slow air exchange. The rough turned bowls and platters are dried over 30 to 60 days.

Checking is kept to a minimum by painting liquid wax (*like Anchorseal*) on the end grain on the inside and outside of the bowl or platter because this slows down drying through the end grain and, thereby, reduces checking. Every week you must weigh each piece and keep a record of the weight. When a piece stops losing weight, it is dry enough to allow you to put the piece back on the lathe for final turning and finishing.

### MATERIALS:

- ◆ 1 Sheet polystyrene unfaced foam board insulation R10 (2" thick by 4 ft by 8 ft); \$34 from Lowe's.
- ◆ 1 sheet of RevolutionPly hardwood plywood (1/4" thick by 4 ft by 8 ft);

\$14 from Lowe's.

- ◆ 1 bottle original Gorilla glue (18 oz.); \$16 from Lowe's.
- ◆ Miscellaneous hinges and hardware; \$15 from Lowe's.
- ◆ Miscellaneous light receptacle, switch box, electrical supplies; \$22 from Lowe's.
- ◆ AC Infinity speed control fan kit AI-80SCX model (maximum speed at 80 cfm); \$21 from [www.amazon.com](http://www.amazon.com)
- ◆ LUX Model LV11 single in-line pole heating thermostat; \$17 from Krell Distribution in Syracuse.

Total cost about \$140

### CONSTRUCTION:

The overall box is about 24" square and 48" tall. Extra pieces (*already on hand*) where used for the top and bottom foam to add to the purchased sheet and to maximize the box size (sides were approximately 24" by 48" pieces). The foam sheet was cut with a power saw and a straight edge. Wear a dust mask when cutting because of all the small foam particles.

Continued on Page 27

## WOOD DRYING BOX, PAGE 2

Assemble foam to foam edges and plywood to foam with Gorilla glue only. It is the best use of Gorilla glue I have ever encountered. Clamp the pieces lightly to hold them in position while the glue dries.

Glue on plywood panels to add strength. Also, add some pine pieces on the edges to protect the box and give you some place to attach hinges. All pine for extra pieces were scraps from shop.

Inside wood racks were all made from scraps and glued together with Gorilla glue.



### OTHER THOUGHTS ON DRYING BLANKS FOR TURNING:

- ⇒ You can turn wet wood but it could distort as it dries.
- ⇒ **You Do Not Need a Box to Dry Blanks.** You can pre-turn a piece and let it passively dry over 12 to 24 months. For this method, create an inside and outside shape in the general form of the final piece. The thickness of the piece should be about 10% of the platter or bowl diameter. Remove from the lathe and coat both sides with liquid wax (like Anchorseal). Put the piece in a paper bag (*not plastic*) and place it somewhere to allow to dry slowly. Be sure to mark the bag with the species of wood, date, and moisture percentage (*use a moisture meter*) and/or weight of the piece. Check the moisture content periodically until it is 10% or the weight no longer declines.

## FINISHING—WARM & DRY BEATS COOL & DAMP

### Application Ranges for Common Finishes

| Finish        | Temperature F | Humidity |
|---------------|---------------|----------|
| Lacquer       | 50-90°        | 25-55%   |
| Oil / Varnish | 40-100°       | 25-55%   |
| Polyurethane  | 50-90°        | 25-55%   |
| Shellac *     | 40-80°        | <85%     |
| Water-based   | 60-100°       | 25-50%   |

\* Do not apply when temperature is within 10° of the dew point.



## YOUR HELP STILL NEEDED!

The June 2023 newsletter presented a strong request for help from the members to help keep our great organization going. We had some great response, especially from many of our newer members. Thank you for stepping forward to offer help. It is great to see so many members helping at each of the meetings since our request. Thank you. And, the emails of support and concern were lovely also.

Was that enough? **NOT REALLY**. We still need more members to come forward to help with not only the video system but also with many other tasks that happen in the club. the goal remains – **HAVE A GREAT CLUB WHERE EVERYONE LEARNS, HAS A GOOD TIME, AND THE WORK IS SHARED AMONG MANY, NOT JUST A FEW!**

### What can you do? *Step Up to Help*

- ◆ **First & Foremost** ... Before you make derogatory comments or criticize something, think about what you did to help and think about what others have done to provide you with regular programs, activities, and a great local woodworking club where you can learn and interact with fellow woodworkers.
- ◆ Offer to help with the audiovisual system at meetings.
- ◆ Come early to meetings to help with room setup and/or stay after a meeting to help with clean-up.
- ◆ Offer to help with or even lead projects or other events.
- ◆ Offer to demonstrate on a topic. Not sure? Team up with someone else. All of the SIG Chairs are looking to fill their demo schedule! Here are their names and contact info:

Gary Morison, Carvers — (315) 327-9157

Barbara Raymond-LaPrease, Scrollers — (315) 345-5381

Mark Anastas, Turners — (315) 863-4483

Charlie LaPrease, Woodworkers — (315) 720-7151

- ◆ Help locate demonstrators and coordinate their demo for the club. Remember, there are 4 different Special Interest Groups and demos can be at any of them!
- ◆ Make tops for the Fair – Each year we need at least 500, preferably 600 or more. While we had enough for 2023, it is never to late to start on your tops for 2024. (*see page 13*)
- ◆ Make a Beads of Courage box for kids being helped at the Joslyn Diabetes Center. (*see page 12*)
- ◆ Make & donate product for the *Crafts for Charity* events (*page 26*).
- ◆ Help out at future *Crafts for Charity* event—setup, selling, demoing when appropriate, pack-up, etc.
- ◆ Provide content – articles, tips, etc. for the newsletter.
- ◆ Offer to be on the Board of Directors as an At-Large member or step up to be a SIG Leader or Officer.
- ◆ Offer to demonstrate at the NYS Farm Show (February 22-24) or at Maker Fair 2024 on May 4<sup>th</sup>.



## WOODWORKERS OF CENTRAL NEW YORK

Membership in the Woodworkers of Central New York, Inc. is open to anyone interested in all genres of woodworking.

Membership covers all Special Interest Groups – Carvers, Scrollers, Turners, & Woodworkers. No additional fee is needed to participate in these Committees unless there is a workshop fee.

There are several types of members:

- ◆ Individual Membership: \$25
- ◆ Family Membership (all living at the same address): \$35
- ◆ Junior Membership (Ages 8-17): Free with adult membership
- ◆ One Day Membership: \$5
- ◆ Honorary Membership: Board Selection

Membership applications are available on the website [www.woodcny.org](http://www.woodcny.org).

Badges are an additional \$9 per person with a \$2 charge to mail the badge.

The Corporation leadership, with contact information, is listed right as a reference. Feel free to contact any club leader to ask questions, suggest programs, or deal with issues.

You should have an active email address if you are a member as the leadership sends many member communications via email as well as this newsletter. To read the newsletter you need to have a PDF reader product such as [Adobe Acrobat Reader](#) installed on your computer. Adobe Reader is free. Due to its size, we prefer not to send newsletters by mail unless specifically requested.

The Woodworkers of CNY was formed in September 2017, to combine the three existing woodworking groups in Central New York into one consolidated entity. Four Committees of the Corporation (aka Special Interest Groups) focus member's attention on three specific genres—carving, scrolling, & turning—as well as the broader, all-encompassing general woodworking area. Members may attend any of the meetings at no additional charge (unless there is a project or speaker charge).



The Woodworkers of CNY was reaccepted as a chapter of the American Association of Woodturners (AAW) in May 2018. We encourage you to join AAW as it is an excellent organization with great resources as a member. Membership in AAW costs either \$56 for an online only or \$68 for a paper-based membership. Each membership includes the 6 issues of the journal, *American Woodturner*, with the online membership receiving it only online. You also have access to a large collection of online resources such as the publication *AAW Fundamentals* which is published on the off months from the journal.



AAW is an international organization of over 14,000 members of varying woodturning skills. In addition to receiving current issues of the journal, *American Woodturner*, membership also provides online access to all past issues of the Journal from 1986 forward. Access to a Resource Directory is also available only to members. Members of AAW also receive savings of up to 50% on AAW merchandise, including project books, DVDs, logo apparel, and more. Members can apply for an educational opportunity grant whereby an individual can receive compensation toward woodturning education for expenses such as tuition, registration, travel, lodging, meals, etc. They can also apply for professional outreach program fellowship grants to encourage creative growth or research, or to provide inspiration for new directions in turned wood art. The AAW Forum is also available to members as are other restricted articles and resources on the AAW website. Members receive a discount on registration for the annual Symposium which is in Louisville, Kentucky in 2023. Check out the AAW website - [www.woodturner.org](http://www.woodturner.org).

**Woodworkers of Central  
New York, Inc.**  
3405 Patchett Rd  
Baldwinsville, NY 13027

### Woodworkers of Central New York, Inc.

#### Leadership

[Doug North](#), President  
(315) 753-1121

[Larry Prunotto](#), Vice President  
(315) 652-3605

[Barbara Raymond-LaPrease](#),  
Secretary (315) 345-5381

[Brad Rees](#), Treasurer  
(315) 391-2723

#### Special Interest Groups Chairs

[Gary Morison](#), Carvers  
(315) 327-9157

Barbara, Scrollers  
(315) 345-5381

[Mark Anastas](#), Turners  
(315) 863-4483

[Charlie LaPrease](#), Woodworkers  
(315) 720-7151

#### At-Large Board Members

[Kerry Kopkey](#) (315) 593-6914

[Robert Love](#) (315) 297-4224

[Bruce Meissner](#) (315) 699-3671

[Rod Castle](#) (315) 638-2659

[Todd Reilly](#) (315) 263-3410

[Arlene Schlueter](#) (315) 720-6633

[Mel Taber](#) (315) 487-7855

[Paul Tennant](#) (315) 676-3469

#### Board Committees

*Financial Oversight*  
Larry Prunotto (chair)

*Charitable Giving*  
Susan Allen (chair)

*Nominating*  
Chad Dawson (chair)

*Web & Social Media*  
Robert Love (chair)

*New York State Fair*  
Barbara Raymond-LaPrease  
(chair)

*Facebook*  
Todd Reilly

*Newsletter Editor*  
[Barbara Raymond-LaPrease](#)



**WE ESPECIALLY NEED**

- Needle Boxes
- Whistles
- Pens
- Sea Urchin Ornaments
- Bird Houses
- Kitchenware esp. Ice Cream Scoops
- Screwdrivers
- Music Boxes
- Letter Openers
- Small Clocks

**CHARITIES WHO RECEIVED PROCEEDS OF 2023 CRAFT SALES**

*Charity for Children*

*McMahon Ryan Child Advocacy Center*

**CRAFTS FOR CHARITIES – DONATIONS NEEDED**

As stated earlier in the newsletter, the club supports local children’s charities by donating money made from the sale of crafts donated by its members at 3-5 locations yearly.

People ask what they can donate. Most anything is happily accepted. We received 4 music boxes before the Manlius Show and they were gone by noon on Saturday. Here are some of the typical items we are looking for in non-ornaments, scrolled, and turned. Carved? Always looking for items. Woodworkers ... Small boxes are one idea and I know there are others!

**Non-Ornament Items:**

|                                |                       |                               |                  |                      |
|--------------------------------|-----------------------|-------------------------------|------------------|----------------------|
| Small Cars/Trucks/Planes, etc. | Small Vases/Weed Pots | Candlestick/Tea Light Holders | Ice Cream Scoops | Small Cutting Boards |
| Small Puzzles                  | Pens                  | Rattles                       | Wizard Wands     | Magnets              |
| Small Boxes                    | Small Clocks          | Seam Rippers                  | Letter Openers   | Screw Drivers        |
| Light Pulls                    | Keychains             | Ring Holders                  | Magnets          | Yo-Yos               |
| Small Bowls                    | Various Kitchen Ware  | Magnifiers                    | Kaleidoscopes    | Snowmen              |

**Scrolled Ornaments:** Most any ornaments are welcome. We have plenty of smaller flat crosses. We need a variety of flat scrolled ornaments like:

|  |  |  |
|--|--|--|
| Angels, Santas, Elves, Snowmen, & Other Holiday Related  | Transportation Images like Trains, Planes, Cars  | Service Groups like Firemen, Policemen, EMS, & All Military  |
| Birds like Hummingbirds, Cardinals, Eagles, Owls, Penguins, Chickadees, etc.   | Fish, Bugs, Ladybugs, Butterflies, Flowers, Trees (Palm Tree), Other Flora, Whales, Shark, Octopus, etc. | Animals like Horses, Dogs, Cats, Elephants, Lions, Bears, Koala Bears, Hedgehogs, Dinosaurs, Dragons, Tigers |
| Sports esp. <i>non-standard</i> ones like Lacrosse, Snowboarding, Cycling, Wrestling, Volleyball, Ballet, Dance, Fencing, Sailing, Field Hockey, Crew, but also Baseball, Basketball, Football, Soccer, Field Hockey, Cycling, Hockey, Skiing, Running, Golf, Gymnastics, etc. |  |  |

**Turned Ornaments – Here are a few ideas:**

|              |                               |  |
|--------------|-------------------------------|--|
| Sea Urchins  | Hollow Balls with Finials     | Bird Houses  |
| Angels       | Light Bulbs of Multiple Sizes | Small Lighthouses  |
| Drums, Bells | Trains                        | Snowmen of All Types & Shapes<br><i>Can Stand Alone or Hang as an Ornament</i> |
| Lollipops    | Ice Cream Cones               | Acorns, Mushrooms  |
| Gnomes/Gonks | Trees—regular & windswept     | Sleds with People On   |

**Holiday-Related Items –** We need multi-piece nativity scenes. We need larger crosses (6-12”) and have plenty of smaller ones. We need angels. We could use items depicting the 12 days of Christmas, esp. *Partridge in a Pear Tree*. We only have dreidels for patrons of the Jewish faith.

**Making Small Toys?** Consider leaving them unfinished and providing a cheap paint set or crayons for the kids to decorate their own!

## VIDEOS OF PAST DEMONSTRATIONS

One of the benefits of your membership being able to access videos of past demonstrations. While they are housed on YouTube, you can only access these videos from the *Member Only* section of the website using a password that changes yearly on April 1<sup>st</sup>.

The videos are arranged by year and month with a page for each year and links from year to year. A brief summary of the video is provided and any documents related to the video are linked right on the page (see sample right).

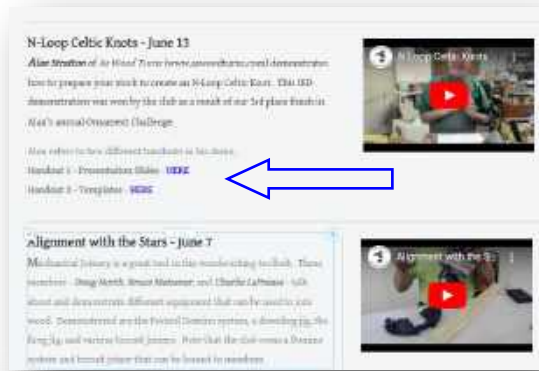

How can you find a past video? On the *Member Only—Videos* landing page, there is a table that identifies the available videos (see right). It is organized by month and Special Interest Group

|                |   |   |   |
|----------------|---|---|---|
| September 2020 | Marbling & Milk Paint with Barbara Rzymowiak-Lafosse<br>[Video Currently Unavailable] | Small Covered Boxes with Embellishments with Chad Davison | none  |
| October 2020   | Turning an Antique Peppermill with Rod Currie   | German Ring Turning with John Maderzi                     | Scrolling Basics with Barbara Rzymowiak-Lafosse |
| November       | Power Tool Safety - The Table Saw & Miter Saw   | Turning a Small Hat                                       | Scrolling Next Steps                            |

sponsoring the demonstration. It is fully searchable within your web browser! With the page open, press the key combination of **CTRL F**. A box will open along the top of the page and you can type in the topic.

Remember, you must have the current password to access the *Members Only* area. It's been sent out with the "News" items in the past. If you don't have it, send a request to [woodcny@gmail.com](mailto:woodcny@gmail.com) for the current password.

## SENDING PHOTOS

We love photos of your projects! We use them for this newsletter, for the online *Show & Tell*, for our website, and for our club slide show.

### HOW DO YOU SEND PHOTOS? HERE ARE THREE (3) WAYS:

Send the Photo by **Email** to the club email: [woodcny@gmail.com](mailto:woodcny@gmail.com). Add any additional information in the email that tells others about your project.

**Text the Photo** to Barbara's cell (315-345-5381) along with information. Remember, be sure to identify yourself!

**Got Lots of Photos?** Use a free product called **WeTransfer** [here](#) to send multiple photos. You can also use the *WeTransfer* app from your phone.

### WHAT ELSE SHOULD I SEND WITH PHOTOS?

With your photos, please send information about the projects shown in the photos – a brief description that should include wood used, finish, and any other information that makes it unique, even stories about the photos.



## Need Sandpaper or Other Supplies?

Call Charlie to Schedule a Time to Visit Eight Acres to Purchase or Come on Workshop Days



## CORPORATION SUPPLIES, LOANS, & SALES

We added some project kits to our inventory—**Pizza Cutters, Ice Cream Scoops, Bottle Openers.** We are hoping you will purchase the kits in sets of 2—You buy one for yourself and one that you make and donate to the club for our *Crafts for Charity* sales.

### CONSUMABLES FOR SALE:

- ◆ **White Abrasive Pads** (1200-1600 grit) [for applying finishes like Osmo] \$2 each
- ◆ **4 x 1/4" Pan Head Screws**—perfect for use with sawtooth hangers—Bag of 20 for \$1.25
- ◆ **Sawtooth Hanger**—9/16"x5/16" or 7/8"x5/16"
  - ◆ Bag of 10 for \$0.50
- ◆ **Miniature Drill Bits**
  - ◆ 1/16" (#52), 3/64" (#56), & 1/32" (#68)
  - ◆ 10 per package—\$6.50 per package
- ◆ **Drill Chuck Adapter for Miniature Bits**
  - ◆ \$11 each
- ◆ **Screw Eyes**—bag of 100 is \$1
- ◆ **Carborundum Sandpaper Sheets**
  - ◆ 80, 100, 120, 180, 240, 320, 400, 600, 800, and 1000 grit
  - ◆ \$1 per sheet or 6 sheets for \$5
- ◆ **Carborundum Sanding Pads—\$2 per pad**
  - ◆ Grits – medium (120-180), fine (320-400), superfine (500-600), ultrafine (800-1000), & microfine (1200-1500)
- ◆ **Sanding Discs from Woodturners Wonders**—bags priced
  - ◆ Purple in 1", 2" or 3"
  - ◆ Wonder Weave in 2" or 3"
  - ◆ Green Wave Oversized in 2"

- ◆ Packaged in bags or 5 of lower grits: 60, 80, 120, 180, 240, 320, 400, & 600 or higher: 800, 1200, 1500, 2000, & 3000
- ◆ **Sanding Pad Holder Kits & Rolac Kits**
  - ◆ 2" & 3" sizes—bags priced
- ◆ **Anchor Seal**
  - ◆ Seals end grain of green wood to encourage slower drying **New Price 4/1/2023**
  - ◆ **\$12 per gallon jug**
  - ◆ Available at meetings if you call Charlie LaPrease (315-720-7151) one day ahead
  - ◆ Also available at Eight Acres by appt.

NOTE: All prices include sales tax which the Corporation pays on an annual basis to New York State.

### TOOL LOAN PROGRAM

The Corporation owns a variety of equipment that members can borrow of a **maximum of one (1) month** at a time. This program is a way for beginners—or even seasoned woodworkers—to experiment with tools before purchasing. Some tools are stored at the Eight Acres Workshop while others, like the carving tools, are not. If you have an interest in borrowing tools, please send an email to [woodcny@gmail.com](mailto:woodcny@gmail.com). Your request will be directed and answered as appropriate.

With recent donations by members, we are expanding our collection of traditional tools and will be making more of those available for loan or even use at Eight Acres during both workshops and times scheduled with Charlie. Need something? Please ask!

## SHARPENING SERVICES

Where can you get table saw blades and other tools sharpened?

**Ken of All Around Sharpening Services** is located in Jordan but you can drop off your items for sharpening at the Baldwinsville Supply which is at 82 East Genesee St (aka Rt 31, just east of the railroad tracks). Ken's cell phone is (315) 689-3184. Email is [sharpeningguy@twcny.rr.com](mailto:sharpeningguy@twcny.rr.com).

**Paul E. Hart** runs a service at 118 Fish Road, Mexico, NY 13114. The phone number is (315) 936-1880. Drop box at new address but picks up blades, etc. at Wiley Lumber & Doow Lumber in East Syracuse as well as Tracy Lumber & Ace Hardware in Fayetteville.

## AMERICAN ASSOCIATION OF WOODTURNERS

### WHY SHOULD I JOIN?

You enjoy woodturning and want more. Your club, the Woodworkers of Central New York, is a chapter of the American Association of Woodturners – AAW. What does that mean for you as a member of our club?

AAW offers the club officers access to a variety of resources from the AAW to help manage the club, including a negotiated reduced price for our corporation's liability insurance. We pay nothing else to AAW to be a chapter.

So what's in it for you? There are many great tools available to you as a member of AAW. You can explore the AAW website to learn about all

the resources you receive with your membership. Two of the biggest is the bi-monthly journal, *American Woodturner*, and the online only product, four issues of *Woodturning FUNDamentals*.

**What's the Cost? \$68 per year**

That's the cost if you want to receive a physical journal. If not, pay \$56 per year.

For each family member (associate), you pay an additional \$5.

Students aged 10-25 pay just \$34 annually for their membership

Join Today [here!](#)



## IN-PERSON WOODWORKING CLASSES

We are listed a few of the "local" craft/woodworking schools that hold classes on a variety of topics. As usual, checking a organization's website and/or calling the is the best way to verify class availability.

### Adirondack Folk School

Lake Luzerne, New York

[www.adirondackfolkschool.org](http://www.adirondackfolkschool.org)

### Appalachian Center for Craft

Smithville, Tennessee

[www.tntech.edu/fine-arts/craftcenter](http://www.tntech.edu/fine-arts/craftcenter)

### Arrowmont School of Arts & Crafts

Gatlinburg, Tennessee

[www.arrowmont.org](http://www.arrowmont.org)

### Connecticut Valley School of Woodworking

Manchester, Connecticut

[schoolofwoodworking.com](http://schoolofwoodworking.com)

### Florida School of Woodwork

Tampa, Florida

[schoolofwoodwork.com](http://schoolofwoodwork.com)

### John C. Campbell Folk School

Brasstown, North Carolina

[folkschool.org](http://folkschool.org)

### Marc Adams School of Woodworking

North Franklin, Indiana

[www.marcadams.com](http://www.marcadams.com)

### Pocosin Arts School of Fine Craft

Columbia, North Carolina

[pocosinarts.org](http://pocosinarts.org)

### Snow Farm / The NE Craft Program

Williamsburg, Massachusetts

[www.snowfarm.org](http://www.snowfarm.org)

### The Woodright's School

Roy Underhill's school

Pittsboro, North Carolina

[www.woodwrightschool.com](http://www.woodwrightschool.com)

### The Woodworking School at Pine Croft

Connected with Berea College; the

former Kelly Mehler school

Berea, Kentucky

[pinecroftwoodschoool.com](http://pinecroftwoodschoool.com)

Do you know of other schools?

Please send the information to [woodcny@gmail.com](mailto:woodcny@gmail.com).

## CLASSES, EVENTS, & SYMPOSIUMS

### REGIONAL CLUB ACTIVITIES



#### Finger Lakes Woodturners

Meetings of the Finger Lakes Woodturners are a combination of in-person and remote demonstrations. They generally hold their meetings on the 3<sup>rd</sup> Thursday of the month and events are held in the shop space at **St. Michael's Workshop, 691 St. Paul St, Rochester**. Their website is: [Here](#).

Their next event is demonstration by member Cliff Weatherall on fluting on the lathe and how various techniques can be applied to a variety of turned projects. The event can be attended via Zoom for members or in person



#### Rochester Woodworkers Society

The Rochester Woodworkers Society hosts a variety of events on an ongoing basis with their national meetings held in the auditorium of Basil Hall at St. John Fisher University. Go to their website [RWS Website](#) has more info.

Their next *national meeting* is a talk on February 16 at 7:30pm by [Ken Page](#) about the Wendell Castle Workshop (aka school) in Scottsville and a retrospective of the body of work by Mr. Castle. There is a *workshop* on Saturday that is a tour of the school. You must register for one of the tour times and be a member.



#### Genesee Valley Woodcarvers

The Genesee Valley Woodcarvers meet on the 2nd Monday of the month at the 40/8 Club, 933 University Ave, Rochester. Their next meeting is February 12<sup>th</sup>. Check their website for more information and to join, etc. — [GVW website](#)

### OTHER EVENTS OF INTEREST

#### Florida Woodturning Symposium

February 16-18, RP Funding Center, Lakeland, FL

Website: [here](#)

#### Wonders in Wood, Woodcarving Show, Sale & Competition

March 9-10, 2024, Millersville University, Millersville, PA

Website: [here](#)

#### Northeastern Woodworkers Association Showcase & Totally Turning

March 23-25, 2024, Saratoga Springs City Center

Website: [here](#)

#### American Association of Woodturners (AAW) 2024 Symposium

May 23-26, 2024, Portland, OR

Website: [here](#)

#### Northeast Woodcarvers Roundup

July 19-24, Cherry Ridge Campsite, Honesdale, PA

Website: [here](#)

#### 25th Anniversary Midwest Scroll Saw & Woodworking Trade Show

August 2-3, Dubuque County Fairgrounds, Dubuque, Iowa

Website: [here](#)

#### Mid-Atlantic Woodturners Symposium

September 20-22, 2024, Marriott, Lancaster, PA

Website: [here](#)



## DIRECTIONS TO EVENT LOCATIONS

Always check the website to identify the location of events. It has the latest information. Club Workshops are held at the *Eight Acres Event Center*, a private home near the North Area YMCA, east of Baldwinsville, NY. The address is available by request: [woodcny@gmail.com](mailto:woodcny@gmail.com)

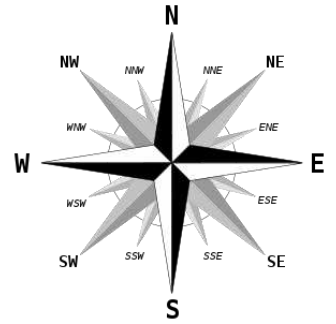

## CARVERS DEMONSTRATIONS/EVENTS

The Carvers meet in the large Community Room at the [Beaver Lake Nature Center, 8477 East Mud Lake Road, Baldwinsville, NY.](#)

The Nature Center is located west of the Village of Baldwinsville and west of Route 690 North. Mud Lake Road is about 1 3/4 miles west from the 690 exit ramp for Route 370. There is an animal hospital just past Mud Lake Road across the street. The entrance to the park is about 1/3 of a mile from your turn onto Mud Lake Road.

The entrance is on the left. Follow the roadway in, wait for the traffic arm to raise and park in either of the lots. Walk to the main building, enter, turn right, and then right again into the large room.

After meetings end, you will exit by the same roadway. If the traffic arm is down, buzz the desk and tell who answers you are with the carvers. They will lift the gate for you to drive through. There is no charge for parking.

## WOODWORKING, TURNING, & SCROLLING, ETC. DEMONSTRATIONS/EVENTS

For any demonstrations and/or events held in the [Community Room at Station 1 of the Belgium Cold Springs Fire Department, 7920 River Road, Baldwinsville, NY...](#)

The **fire station** is located southeast of Baldwinsville just south of the intersection of three roads—River Road, Hicks Road, and Patchett Rd.— off River Rd.

If you take Rt 370 north from John Glenn Blvd, River Rd is the first right after going across the bridge. The firehouse is 2 miles from that turn. You can also go to the traffic light on Rt 370 which is Hicks Rd, and make a turn onto Hicks (head up the hill).

If you are coming from Rt. 31, take a left onto River Rd (on the west side of Belgium Bridge), and head south about 2 miles past the new YMCA.

**Please be aware that when attending meetings or events at the firehouse, DO NOT park on the grass or in front of the firehouse bay doors, or park such that others cannot enter the parking lot.** If there is an alarm, the firefighters will drive right over your vehicle if it is in the way. The septic system is in the grassy areas. There is plenty of street parking. The Community Room entrance is on the **north** side of the building.

**Do Not Drive or  
Park on the Grass!**

*Schedules subject  
to change*

## MEETINGS SCHEDULES

### WOODWORKERS SIG SPONSORED DEMOS—2024

| Date                                 | Topic  | Demonstrator/Speaker |
|--------------------------------------|--|----------------------|
| January 3rd                          | Basics of Veneering  | Terry Dote           |
| February 7th                         | The Little Red Wagon   | Jim Yonkers          |
| March 6th                            | Using the Club's Akeda Dovetail Jig  | David Wheat          |
| April 3rd                            | TBD  |                      |
| May 1st                              | TBD  |                      |
| June 5th                             | TBD  |                      |
| July 10th                            | TBD  |                      |
| August 7th                           | TBD  |                      |
| September 4th                        | TBD  |                      |
| <b>Saturday<br/>October 19th</b>     | <b>18<sup>th</sup> Woodworkers Challenge</b><br><i>All Members Plan to Participate in this Annual Competition!</i> |                      |
| November 6th                         | TBD  |                      |
| Sunday,<br>December 8th <sup>d</sup> | <i>Holiday Event &amp; Annual Meeting — One Party for All Members</i>  |                      |

**NOTE:**

The date for the Annual Woodworkers Challenge now October 19th to encourage greater participation!

### TURNERS SIG SPONSORED DEMOS—2024

| Date                               | Topic   | Demonstrator                   | Challenge           |
|------------------------------------|---|--------------------------------|---------------------|
| January 9th                        | Embellishing Your Projects  | Robert Love                    | Make a Lamp         |
| February 13th                      | Turning a Peppermill  | Rod Castle                     | Embellished Project |
| March 12th                         | Creating the Top Gameboard  | Jim Ruddock                    | Peppermill          |
| April 9th                          | Woodshop First Aid & Shop Fire Prevention   | John McCabe / Charlie LaPrease | Top Gameboard       |
| May 14th                           | Turning a Finial  | Larry Prunotto                 | Ornament            |
| June 11th                          | TBD   |                                |                     |
| July 9th                           | TBD   |                                |                     |
| August 13th                        | TBD   |                                |                     |
| September 10th                     | TBD   |                                |                     |
| <b>Saturday, October<br/>19th.</b> | <b>18<sup>h</sup> Woodworkers Challenge</b><br><i>All Members Plan to Participate in this Annual Competition!</i> |                                |                     |
| November 12th                      | TBD   |                                |                     |
| Sunday,<br>December 8th            | <i>Holiday Event &amp; Annual Meeting — One Party for All Members</i>   |                                |                     |



## MEETINGS SCHEDULES

### CARVERS SPONSORED DEMOS/CLASSES—2024

| Date                          | Topic   |
|-------------------------------|---|
| January 18th                  | <b>Carving a Rose, Part 1</b> with Gary Morison   |
| February 15th                 | <b>Carving a Rose, Part 1</b> with Gary Morison   |
| March 21st                    | <b>Carving a Rose, Part 1</b> with Gary Morison   |
| April 18th                    | TBD   |
| May 16th                      | TBD   |
| June 20th                     | TBD with Frank Huckabone  |
| July 18th?                    | TBD with Mike Bloomquist  |
| August 15th                   | TBD with Mike Bloomquist  |
| September 19th                | TBD with Dave Weir  |
| <b>Saturday, October 19th</b> | <b>18th Woodworkers Challenge</b><br><i>All Members Plan to Participate in this Annual Competition!</i> |
| November 21st                 | TBD with Arlene Schlueter   |
| Sunday, December 8th          | <i>Holiday Event — One Party for All Members</i>  |

*Schedules subject to change*

**NOTE:**

The date for the Annual Woodworkers Challenge now October 19th to encourage greater participation!

### SCROLLERS SIG SPONSORED DEMOS—2024

| Date                          | Topic   | Challenge             |
|-------------------------------|---|-----------------------|
| February 21st                 | <b>Compound Cutting</b>   | Ring Basket / Bowl    |
| April 17th                    | <b>3D Puzzles</b>   | Compound Cut Projects |
| June 19th <sup>†</sup>        | <b>Layered Projects</b>   | 3D Puzzle             |
| September 18th                | <b>TBD</b>  | Layered Project       |
| <b>Saturday, October 19th</b> | <b>18th Woodworkers Challenge</b><br><i>All Members Plan to Participate in this Annual Competition!</i> |                       |
| November 20th                 | <b>TBD</b>  |                       |
| Sunday, December 8th          | <i>Holiday Event &amp; Annual Meeting — One Party for All Members</i>                                   |                       |

### 2024 SATURDAY WORKSHOPS

|              |             |             |              |
|--------------|-------------|-------------|--------------|
| January 13   | February 17 | March 16    | April 13     |
| May 18       | June 15     | July 13     | August 17    |
| September 14 | October 12  | November 16 | December 14? |

**Note:** Workshop dates are subject to change due to a variety of factors. Always check the website for the correct date!

## CLASSIFIEDS

**FOR SALE: FIGURED HARD MAPLE BOARDS** — Approximately 110 board feet of figured hard maple (striped and Birdseye, intensity of figure ranges from moderate to strong), 6/4 & 8/4, 4ft.-8ft.lengths. Wood has been stored indoors for up to thirty-five years. Most of the boards are completely defect-free and all have recently been inspected for possible powder post beetle damage. Sold only as a single lot, \$800 (approx. \$7.25 per bd.ft.), local pickup. Please call Barry Gordon at 315-857-4179, 10:00AM-7:00PM any day.

**FREE—Old Rockwell-Delta Floor Model Drill Press** with 1/2" chuck in working order. Call Clarence (Fibber) Magee @516-524-1382 or at fibber.magee@gmail.com. Located outside of Greene, NY. *Going to junk if no one wants!*

**FREE— 8 Foot Long T2 Single Pole Fluorescent Tubes** (Qty 12) - Used but still working. Contact George Lorefice at 315-427-1623 or [loreficegj@gmail.com](mailto:loreficegj@gmail.com)

**FOR SALE—Grizzly 2HP Canister Dust Collector**—steel impeller. \$400. Contact Kevin Rawlings at [hostaguy@gmail.com](mailto:hostaguy@gmail.com)

**FOR SALE—General 3HP Shaper Model 40-250 (220V)** with accessories. Original owner. \$1500. Contact Rick Simmons at [rick2859@yahoo.com](mailto:rick2859@yahoo.com) or 315-876-8338

**WANTED—DRY, Live Edge Hardwood Boards.** Minimum size of 5 inches wide, 12 inches long, and at least 1½" thick. Wider and longer the better. Contact Mel Taber at (315) 487-7855 or [mtaber3@gmail.com](mailto:mtaber3@gmail.com).

**FOR SALE — Used bench vises.** Good quality, commercial grade. Price \$50 to \$75 each. For more info, email **Bud Millis** at (315) 297-7525 or [emillis@twcny.rr.com](mailto:emillis@twcny.rr.com)

**FOR SALE — LUMBER — Kiln & Air Dried Hardwoods** (PA cherry, chestnut, maple, white oak, butternut, etc.) & some softwoods available. Also Black Walnut and English Walnut slabs available. Contact **Bud Millis** at (315) 297-7525 or [emillis@twcny.rr.com](mailto:emillis@twcny.rr.com).

Classifieds are welcome with the caveat that people notify the editor when entries are sold.

### \*\* MEMBER OF CLUB

Also, see various offerings by members in the classifieds above as well as the links on the Wood ID & Suppliers page on the website.

## AREA LUMBER SUPPLIERS

**Custom Hardwood Lumber Co.** 8633 State Route 104  
Hannibal, NY 13074  
(315) 564-3101 Facebook link [here](#)  
[Customhardwoodlumber@gmail.com](mailto:Customhardwoodlumber@gmail.com)

**Dexters Woodshop**  
6949 Kingdom Rd  
Memphis  
(315) 456-8271

**Logs to Lumber**  
720 Church St, Baldwinsville  
(315) 678-2151

**Memphis Hardwood Lumber**  
6535 Church St, Memphis (315) 689-3949  
[www.memphishardwoodlumber.com](http://www.memphishardwoodlumber.com)

**Lakeshore Hardwoods \*\***  
266 Manwaring Rd., Pulaski (315) 298-6407  
191 West Main St, Victor (585) 869-5118  
[www.lakeshorehardwoods.com](http://www.lakeshorehardwoods.com)

**Kennedy Hardwood**  
1939 Clark Rd., Preble (607) 749-7890  
[www.kennedyhardwood.com](http://www.kennedyhardwood.com)

**Liverpool Lumber Company**  
201 North Willow St., Liverpool  
(315) 457-2220  
[liverpool-lumber.com](http://liverpool-lumber.com)

**Pittsford Lumber**  
50 State St., Pittsford (585) 586-1877  
[www.pittsfordlumber.com](http://www.pittsfordlumber.com)

**Tracy Lumber [B.H. Tracy & Sons]**  
550 East Genesee St., Fayetteville  
(315) 637-3174  
[www.tracylumber.com](http://www.tracylumber.com)

**Willey Lumber Company**  
100 Hartwell Ave, East Syracuse  
(315) 437-3344  
[www.willeylumber.com](http://www.willeylumber.com)

**Johnson Brothers Lumber**  
2550 Ballina Rd, Cazenovia (315) 655-8824  
[www.johnsonbrotherslumber.com](http://www.johnsonbrotherslumber.com)

**Salt City Woods, Mill & Kiln**  
715 Old Liverpool Rd — In Back  
Liverpool, NY 13088  
(315) 952-1692  
[derby@saltcitywoods.com](mailto:derby@saltcitywoods.com)  
[saltcitywoods.com](http://saltcitywoods.com)

**Brown Dog Wood Products**  
1379 County Route 4, Central Square  
315-243-8358  
[www.Browndogwoodproducts.com](http://www.Browndogwoodproducts.com)